

Compact I/O Expansion Power Supplies

Catalog Numbers 1769-PA2, 1769-PB2, 1769-PA4,
1769-PB4

Topic	Page
Important User Information	2
Environment and Enclosure	3
North American Hazardous Location Approval	4
Install Safety Circuits	4
European Hazardous Location Approval	5
Before You Begin	6
Assemble the System	9
Mount an I/O Expansion Power Supply	11
Verify Your System Power	14
Power Considerations	15
Use a Master Control Relay	17
Schematic (Using IEC Symbols)	18
Schematic (Using ANSI/CSA Symbols)	19
Connect the Power Supplies	19
Connect Field Wires	21
Replace the Fuse	24
Temperature Derating	25
Power Dissipation	28
Specifications	30
Additional Resources	35

About the Power Supplies

Compact I/O power supplies provide 120/240V AC and 24V DC power to modules, which can be placed to the left or the right side of the 1769 power supply. As many as eight I/O modules can be placed on each side of the power supply.

Important User Information

Solid state equipment has operational characteristics differing from those of electromechanical equipment. Safety Guidelines for the Application, Installation and Maintenance of Solid State Controls (Publication SGI-1.1 available from your local Rockwell Automation sales office or online at <http://literature.rockwellautomation.com>) describes some important differences between solid state equipment and hard-wired electromechanical devices. Because of this difference, and also because of the wide variety of uses for solid state equipment, all persons responsible for applying this equipment must satisfy themselves that each intended application of this equipment is acceptable.





In no event will Rockwell Automation, Inc. be responsible or liable for indirect or consequential damages resulting from the use or application of this equipment.

The examples and diagrams in this manual are included solely for illustrative purposes. Because of the many variables and requirements associated with any particular installation, Rockwell Automation, Inc. cannot assume responsibility or liability for actual use based on the examples and diagrams.

No patent liability is assumed by Rockwell Automation, Inc. with respect to use of information, circuits, equipment, or software described in this manual.

Reproduction of the contents of this manual, in whole or in part, without written permission of Rockwell Automation, Inc., is prohibited.

Throughout this manual, when necessary, we use notes to make you aware of safety considerations.

<p>WARNING</p> 	<p>Identifies information about practices or circumstances that can cause an explosion in a hazardous environment, which may lead to personal injury or death, property damage, or economic loss.</p>
<p>IMPORTANT</p>	<p>Identifies information that is critical for successful application and understanding of the product.</p>
<p>ATTENTION</p> 	<p>Identifies information about practices or circumstances that can lead to personal injury or death, property damage, or economic loss. Attentions help you identify a hazard, avoid a hazard and recognize the consequences.</p>
<p>SHOCK HAZARD</p> 	<p>Labels may be on or inside the equipment (for example, drive or motor) to alert people that dangerous voltage may be present.</p>
<p>BURN HAZARD</p> 	<p>Labels may be on or inside the equipment (for example, drive or motor) to alert people that surfaces may reach dangerous temperatures.</p>

Environment and Enclosure

ATTENTION

This equipment is intended for use in a Pollution Degree 2 industrial environment, in overvoltage Category II applications (as defined in IEC publication 60664-1), at altitudes up to 2000 meters (6562 ft) without derating.

This equipment is considered Group 1, Class A industrial equipment according to IEC/CISPR Publication 11. Without appropriate precautions, there may be potential difficulties ensuring electromagnetic compatibility in other environments due to conducted as well as radiated disturbance.

This equipment is supplied as open-type equipment. It must be mounted within an enclosure that is suitably designed for those specific environmental conditions that will be present and appropriately designed to prevent personal injury resulting from accessibility to live parts. The enclosure must have suitable flame-retardant properties to prevent or minimize the spread of flame, complying with a flame spread rating of 5VA, V2, V1, V0 (or equivalent) if non-metallic. The interior of the enclosure must be accessible only by the use of a tool. Subsequent sections of this publication may contain additional information regarding specific enclosure type ratings that are required to comply with certain product safety certifications.

In addition to this publication, see:

- Industrial Automation Wiring and Grounding Guidelines, for additional installation requirements, Allen-Bradley publication [1770-4.1](#).
- NEMA Standards publication 250 and IEC publication 60529, as applicable, for explanations of the degrees of protection provided by different types of enclosure.



Prevent Electrostatic Discharge

ATTENTION

This equipment is sensitive to electrostatic discharge, which can cause internal damage and affect normal operation. Follow these guidelines when you handle this equipment:

- Touch a grounded object to discharge potential static.
 - Wear an approved grounding wriststrap.
 - Do not touch connectors or pins on component boards.
 - Do not touch circuit components inside the equipment.
 - Use a static-safe workstation, if available.
 - Store the equipment in appropriate static-safe packaging when not in use.
-

North American Hazardous Location Approval

<p>The following information applies when operating this equipment in hazardous locations:</p>	<p>Informations sur l'utilisation de cet équipement en environnements dangereux:</p>
<p>Products marked "CL I, DIV 2, GP A, B, C, D" are suitable for use in Class I Division 2 Groups A, B, C, D, Hazardous Locations and nonhazardous locations only. Each product is supplied with markings on the rating nameplate indicating the hazardous location temperature code. When combining products within a system, the most adverse temperature code (lowest "T" number) may be used to help determine the overall temperature code of the system. Combinations of equipment in your system are subject to investigation by the local Authority Having Jurisdiction at the time of installation.</p>	<p>Les produits marqués "CL I, DIV 2, GP A, B, C, D" ne conviennent qu'à une utilisation en environnements de Classe I Division 2 Groupes A, B, C, D dangereux et non dangereux. Chaque produit est livré avec des marquages sur sa plaque d'identification qui indiquent le code de température pour les environnements dangereux. Lorsque plusieurs produits sont combinés dans un système, le code de température le plus défavorable (code de température le plus faible) peut être utilisé pour déterminer le code de température global du système. Les combinaisons d'équipements dans le système sont sujettes à inspection par les autorités locales qualifiées au moment de l'installation.</p>
<p>WARNING</p> 	<p>EXPLOSION HAZARD -</p> <ul style="list-style-type: none"> Do not disconnect equipment unless power has been removed or the area is known to be nonhazardous. Do not disconnect connections to this equipment unless power has been removed or the area is known to be nonhazardous. Secure any external connections that mate to this equipment by using screws, sliding latches, threaded connectors, or other means provided with this product. Substitution of components may impair suitability for Class I, Division 2. If this product contains batteries, they must only be changed in an area known to be nonhazardous.
<p>AVERTISSEMENT</p> 	<p>RISQUE D'EXPLOSION –</p> <ul style="list-style-type: none"> Couper le courant ou s'assurer que l'environnement est classé non dangereux avant de débrancher l'équipement. Couper le courant ou s'assurer que l'environnement est classé non dangereux avant de débrancher les connecteurs. Fixer tous les connecteurs externes reliés à cet équipement à l'aide de vis, loquets coulissants, connecteurs filetés ou autres moyens fournis avec ce produit. La substitution de composants peut rendre cet équipement inadapté à une utilisation en environnement de Classe I, Division 2. S'assurer que l'environnement est classé non dangereux avant de changer les piles.

Install Safety Circuits

WARNING



Explosion Hazard - Do not connect or disconnect connectors while circuit is live.

Circuits that are installed on the machine for safety reasons, like overtravel limit switches, stop push buttons, and interlocks, should always be hard-wired directly to the master control relay. These devices must be wired in series so that when any one device opens, the master control relay is de-energized, thereby removing power to the machine.

ATTENTION



Never alter these circuits to defeat their function. Serious injury or machine damage could result.

European Hazardous Location Approval

1769-PB2, 1769-PB4 Only

European Zone 2 Certification (The following applies when the product bears the Ex or EEx Marking)

This equipment is intended for use in potentially explosive atmospheres as defined by European Union Directive 94/9/EC and has been found to comply with the Essential Health and Safety Requirements relating to the design and construction of Category 3 equipment intended for use in potentially explosive atmospheres, given in Annex II to this Directive.

Compliance with the Essential Health and Safety Requirements has been assured by compliance with EN 60079-15 and EN 60079-0.

WARNING



- This equipment must be installed in an enclosure providing at least IP54 protection when applied in Zone 2 environments.
- This equipment shall be used within its specified ratings defined by Allen-Bradley.
- Provisions shall be made to prevent the rated voltage from being exceeded by transient disturbances of more than 40% when applied in Zone 2 environments.
- This equipment must be used only with ATEX certified backplanes.
- Secure any external connections that mate to this equipment by using screws, sliding latches, threaded connectors, or other means provided with this product.
- Do not disconnect equipment unless power has been removed or the area is known to be nonhazardous.

ATTENTION



This equipment is not resistant to sunlight or other sources of UV radiation.

Before You Begin

There are some points about power distribution that you should know.

- The master control relay must be able to inhibit all machine motion by removing power to the machine I/O devices when the relay is de-energized. We recommend that the controller remains powered even when the master control relay is de-energized.
- If you are using a DC power supply, interrupt the load side rather than the AC line power. This avoids the additional delay of power supply turn-off. The DC power supply should be powered directly from the fused secondary of the transformer. Power to the DC input and output circuits should be connected through a set of master control relay contacts.

Perform Periodic Tests of Master Control Relay Circuit

Any part can fail, including the switches in a master control relay circuit. The failure of one of these switches would most likely cause an open circuit, which would be a safe power-off failure. However, if one of these switches shorts out, it no longer provides any safety protection. These switches should be tested periodically to assure they will stop machine motion when needed.

Parts Illustration of a Power Supply

The sample illustrations of a 1769-PA4 power supply let you review the various components that comprise a power supply, which is attached to a DIN rail.

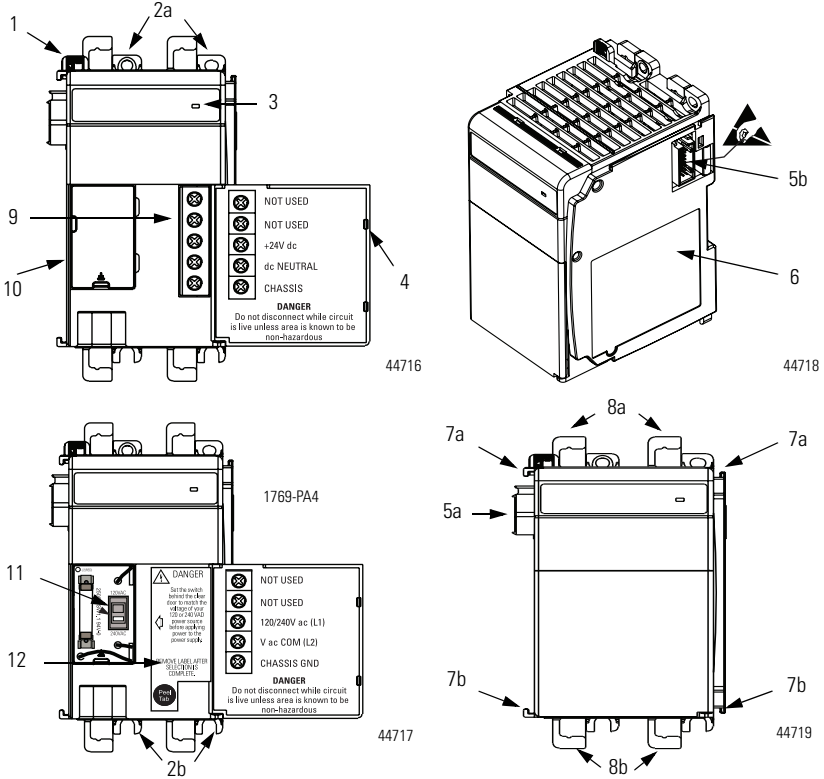

Item	Description
1	Bus lever (with locking function)
2a	Upper panel mounting tabs
2b	Lower panel mounting tabs
3	Status Indicator
4	Power supply door with terminal identification label
5a	Movable bus connector with female pins
5b	Stationary bus connector with male pins
6	Nameplate label

Item	Description
7a	Upper tongue-and-groove slots
7b	Lower tongue-and-groove slots
8a	Upper DIN rail latches
8b	Lower DIN rail latches
9	Terminal block with finger-safe cover
10	Fuse housing cover for replaceable fuse
11	120V AC or 240V AC line input power selector switch (PA4 only)
12	Removable selector switch label (PA4 only)

Install an I/O Expansion Power Supply

Compact I/O Expansion Power Supplies are suitable for use in an industrial environment when installed in accordance with these instructions. Specifically, this equipment is intended for use in clean, dry environments (Pollution degree 2⁽¹⁾) and to circuits not exceeding Over Voltage Category II⁽²⁾ (IEC 60664-1).⁽³⁾

Disconnect the Power

WARNING



Remove power before removing or inserting this power supply from the 1769 I/O system. When you remove or insert a power supply with power applied, an electrical arc may occur. An electrical arc can cause personal injury or property damage by:

- sending an erroneous signal to your system's field devices, causing unintended machine motion.
- causing an explosion in a hazardous environment.

Electrical arcing causes excessive wear to contacts on both the power supply and its mating connector. Worn contacts may create electrical resistance.

(1) Pollution Degree 2 is an environment where, normally, only non-conductive pollution occurs except that occasionally a temporary conductivity caused by condensation shall be expected.

(2) Over Voltage Category II is the load level section of the electrical distribution system. At this level transient voltages are controlled and do not exceed the impulse voltage capability of the product's insulation.

(3) Pollution Degree 2 and Over Voltage Category II are International Electrotechnical Commission (IEC) designations.

Assemble the System

1769 Compact I/O power supplies distribute power from either side of the power supply.

EXAMPLE

A 2 amp at 5V DC power supply (1769-PA2, 1769-PB2) can provide 1 amp to the right side of the power supply and 1 amp to the left. A 4 amp at 5V DC power supply (1769-PA4, 1769-PB4) can provide 2 amps to the right side of the power supply and 2 amps to the left.

The maximum amount of current the system supports in both directions is:

- 1769-PA2, 1769-PB2: 2 amps at 5V DC; 1 amp at 24V DC.
- 1769-PA4, 1769-PB4: 4 amps at 5V DC; 2 amps at 24V DC.

IMPORTANT

The maximum amount of current that can be distributed from either side of any 1769 power supply is 2 amps at 5V DC and 1 amp at 24V DC.

This is a limit of the 1769 Compact I/O Bus.

The power supply can be attached to an adjacent I/O module **before** or **after** mounting.

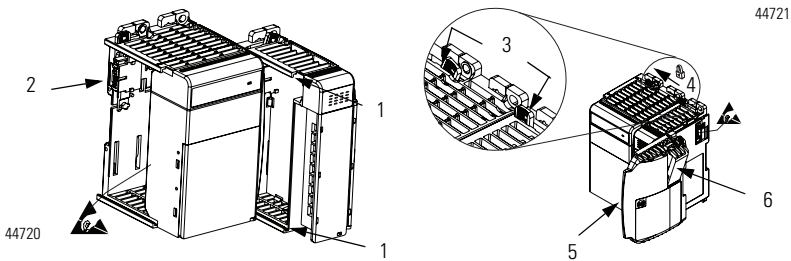

Item	Description
1	Upper and lower tongue-and-groove slots
2	Bus connectors
3	Positioning tab
4	Direction of the bus lever of the power supply to the I/O modules
5	End cap terminator
6	End cap bus terminator

Follow these steps to assemble the Compact I/O system.

1. Disconnect your line power.

The power supply does not support removal or insertion of modules under power.

WARNING

If you connect or disconnect wiring while the field-side power is on, an electrical arc can occur. This could cause an explosion in hazardous location installations. Be sure that power is removed or the area is nonhazardous before proceeding.

-
2. Check that the bus lever of the power supply to be installed is in the unlocked (fully right) position.
 3. Use the upper and lower tongue-and-groove slots to secure the power supply to an I/O module.
 4. Move the power supply back along the tongue-and-groove slots until the bus connectors line up with each other.
 5. Push the bus lever back slightly to clear the positioning tab.

Use your fingers or a small screwdriver.

6. To allow communication between the controller and the I/O, move the bus lever of the power supply and its adjacent I/O modules fully to the left until it clicks.

Make sure it is locked firmly in place.

ATTENTION

When attaching expansion I/O power supplies, it is very important that the bus connectors are securely locked together to ensure proper electrical connection.

-
7. Attach an end cap terminator to the last I/O module in the system by using the tongue-and-groove slots as before.
 8. Lock the end cap bus terminator.

IMPORTANT

A 1769-ECR or 1769-ECL right or left end cap (respectively) must be used to terminate the end of the serial communication bus.

Mount an I/O Expansion Power Supply

ATTENTION



During panel or DIN rail mounting of all devices, be sure that all debris (for example, metal chips, wire strands) is kept from falling into the module. Debris that falls into the module could cause damage on power up.

Minimum Spacing

Maintain spacing from enclosure walls, wireways, adjacent equipment, and so forth. Allow 50 mm (2 in.) of space on all sides for adequate ventilation.

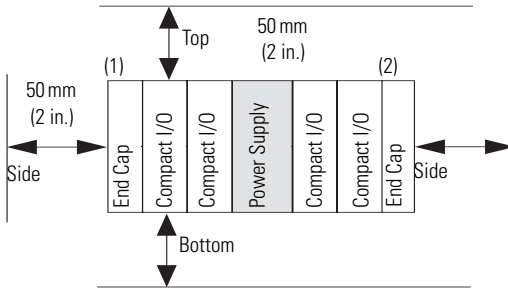

Item	Description
1	This could be an end cap, controller, adapter, or expansion cable depending on your system configuration.
2	This could be an end cap or expansion cable depending on your system configuration.

Prevent Excessive Heat

For most applications, normal convective cooling keeps the system within the specified operating range. Verify that the specified temperature range is maintained. Proper spacing of components within an enclosure is usually sufficient for heat dissipation.

In some applications, a substantial amount of heat is produced by other equipment inside or outside the enclosure. In this case, place blower fans inside the enclosure to assist in air circulation and to reduce hot spots near the system.

Additional cooling provisions might be necessary when high ambient temperatures are encountered.

TIP

Do not bring in unfiltered outside air. Place the Compact I/O system in an enclosure to protect it from a corrosive atmosphere. Harmful contaminants or dirt could cause improper operation or damage to components. In extreme cases, you may need to use air conditioning to protect against heat build-up within the enclosure.

Mount the Panel

Mount the power supply to a panel by using four screws per module. Use M4 or #8 panhead screws. Mounting screws are required on each power supply panel mounting tab.

ATTENTION



This product is intended to be mounted to a well-grounded mounting surface such as a metal panel. Additional grounding connections from the power supply's mounting tabs or DIN rail (if used) are not required unless the mounting surface cannot be grounded. Refer to Industrial Automation Wiring and Grounding Guidelines, Allen-Bradley publication [1770-4.1](#), for additional information.

Panel Mounting Using the Dimensional Template

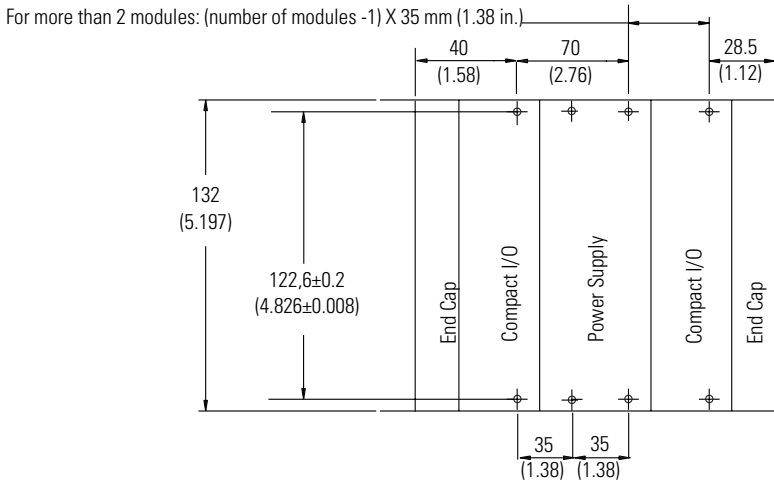

Note: All dimensions are in mm (in.). Hole spacing tolerance: ± 0.4 mm (0.016 in.)

Mount a Power Supply on a DIN Rail

The power supply can be mounted using the following DIN rails:

- 35 x 7.5 mm (EN 50 022 - 35 x 7.5)
- 35 x 15 mm (EN 50 022 - 35 x 15)

1. Before mounting a power supply or module on a DIN rail, close the DIN rail latches.
2. Press the DIN rail mounting area of the module against the DIN rail.

The latches will momentarily open and lock into place. The following illustration shows a power supply being attached to the I/O modules in a DIN rail mounted Compact I/O system.

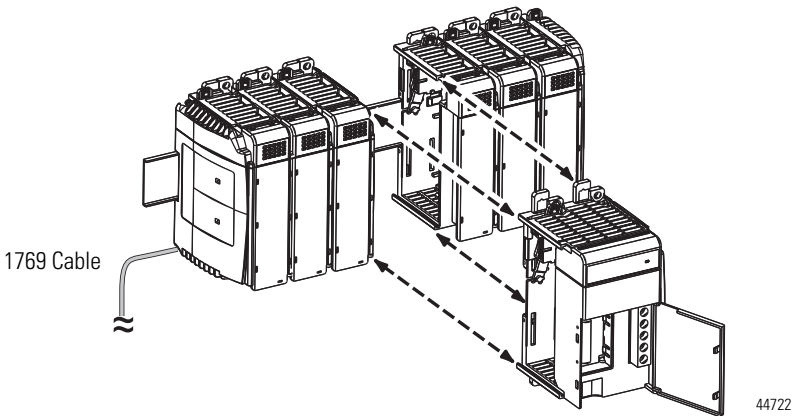

Verify Your System Power

Your system power budget is a consideration when using 1769 power supplies. This determines the power that is being provided to the I/O modules. Refer to Calculate System Power Requirements in the Compact I/O Selection Guide, publication [1769-SG002-EN-P](#), for the power budget calculation worksheet.

TIP

The total number of I/O modules cannot exceed 16 on a single bank with a maximum of 8 I/O modules on either side of the power supply.

When configuring your system using a MicroLogix 1500 controller, only one expansion cable, one expansion power supply and a total of eight I/O modules may be used in a maximum of two banks of I/O modules. The expansion power supply cannot be directly connected to the MicroLogix 1500 controller.

1. After you have reviewed the amount of current consumed by your system, verify that your power supply has adequate capacity for its bank of I/O modules.

See [page 25](#) for graphs.

2. To do so, compare the current graphs to your totals for the following:
 - total 5V DC
 - total 24V DC
 - total 24V DC sensor power (1769-PA2 only)
3. If your power supply load is at or above the limits of the allowable ranges shown in the graphs, you must add an additional I/O bank.

See [Connect the Power Supplies](#) for additional information.

IMPORTANT

An additional I/O bank must include its own power supply.

An end cap/terminator (1769-ECR or 1769-ECL) must also be used if the I/O bank is the last in the system.

Power Considerations

The following sections explain power considerations for the Compact I/O system.

Disconnect the Main Power

WARNING

Explosion Hazard - Do not replace components or disconnect equipment unless power has been switched off.

If you connect or disconnect wiring while the field-side power is on, an electrical arc can occur. This could cause an explosion in hazardous location installations. Be sure that power is removed or the area is nonhazardous before proceeding.

Install the main power disconnect switch where operators and maintenance personnel have quick and easy access to it. Besides disconnecting electrical power, de-energize all other sources of power (pneumatic and hydraulic) before you begin working on a machine or process controlled by a controller.

Isolation Transformer Usage

You may want to use an isolation transformer in the AC line. This type of transformer provides isolation from your power distribution system to reduce electrical noise and is often used as a step down transformer to reduce line voltage. Any transformer used with the Compact I/O system must have a sufficient power rating for its load. The power rating is expressed in volt-amperes (VA). See [Schematic \(Using IEC Symbols\)](#) for an example of circuits using isolation transformers.

Power Supply Inrush

During powerup, the power supply allows a brief inrush current to charge internal capacitors. Many power lines and control transformers can supply inrush current for a brief time. If the power source cannot supply this inrush current, the source voltage may sag momentarily.

The only effect of limited inrush current and voltage sag on the system is that the power supply capacitors charge more slowly. However, the effect of a voltage sag on other equipment should be considered. For example, a deep voltage sag may reset a computer connected to the same power source. The following considerations determine whether the power source must be required to supply high inrush current:

- Power-up sequence of devices in a system
- Amount of the power source voltage sag if the inrush current cannot be supplied
- Effect of voltage sag on other equipment in the system

If the entire system is powered up at the same time, a brief sag in the power source voltage typically will not affect any equipment.

Loss of Power Source

The power supply is designed to withstand brief power losses without affecting the operation of the system. The time the system is operational during power loss is called “program scan hold-up time after loss of power.” The duration of the power supply hold-up time depends on the type and state of the I/O, but is typically between 5 milliseconds...10 seconds. When the duration of power loss reaches this limit, the power supply signals the processor that it can no longer provide adequate DC power to the system. This is referred to as a power supply shutdown. The processor then performs an orderly shutdown of the controller.

Input States on Power Down

The power supply hold-up time is generally longer than the turn-on and turn-off times of the inputs. Because of this, the input state change from ‘On’ to ‘Off’ that occurs when power is removed may be recorded by the processor before the power supply shuts down the system. Understanding this concept is important. The user program should be written to take this effect into account.

Other Types of Line Conditions

Occasionally the power source to the system can be temporarily interrupted. It is also possible that the voltage level may drop substantially below the normal line voltage range for a period of time. Both of these conditions are considered to be a loss of power for the system.

User Power Overcurrent Condition

The power supply shuts down in the event of an overcurrent condition. All outputs latch off and remain off until you remove the overcurrent and cycle power. Reload the user program following a power supply shutdown.

ATTENTION

To avoid unexpected operation due to 24V DC user power shutdown (1769-PA2 only), monitor the 24V DC user output with a 24V DC input channel.

Use a Master Control Relay

A hard-wired master control relay (MCR) provides a reliable means for emergency machine shutdown. Since the master control relay allows the placement of several emergency-stop switches in different locations, its installation is important from a safety standpoint.

Overtravel limit switches or mushroom-head push buttons are wired in series so that when any of them opens, the master control relay is de-energized. This removes power to input and output device circuits.

ATTENTION

Never alter these circuits to defeat their function since serious injury and/or machine damage could result.

TIP

- If you are using an external DC power supply, interrupt the DC output side rather than the AC line side of the supply to avoid the additional delay of power supply turn off.
- The AC line of the DC output power supply should be fused.
- Connect a set of master control relays in series with the DC power supplying the input and output circuits.

Place the main power disconnect switch where operators and maintenance personnel have quick and easy access to it. If you mount a disconnect switch inside the enclosure, place the switch operating handle on the outside of the enclosure, so that you can disconnect power without opening the enclosure.

Whenever any of the emergency-stop switches are opened, power to input and output devices should be removed.

When you use the master control relay to remove power from the external I/O circuits, power continues to be provided to the system's power supply so that diagnostic indicators on the processor can still be observed.

The master control relay is not a substitute for a disconnect to the system. It is intended for any situation where the operator must quickly de-energize only I/O devices. When inspecting or installing terminal connections, replacing output fuses, or working on equipment within the enclosure, use the disconnect to shut off power to the rest of the system.

TIP

Do not control the master control relay with the Compact I/O system. Provide the operator with the safety of a direct connection between an emergency-stop switch and the master control relay.

Schematic (Using IEC Symbols)

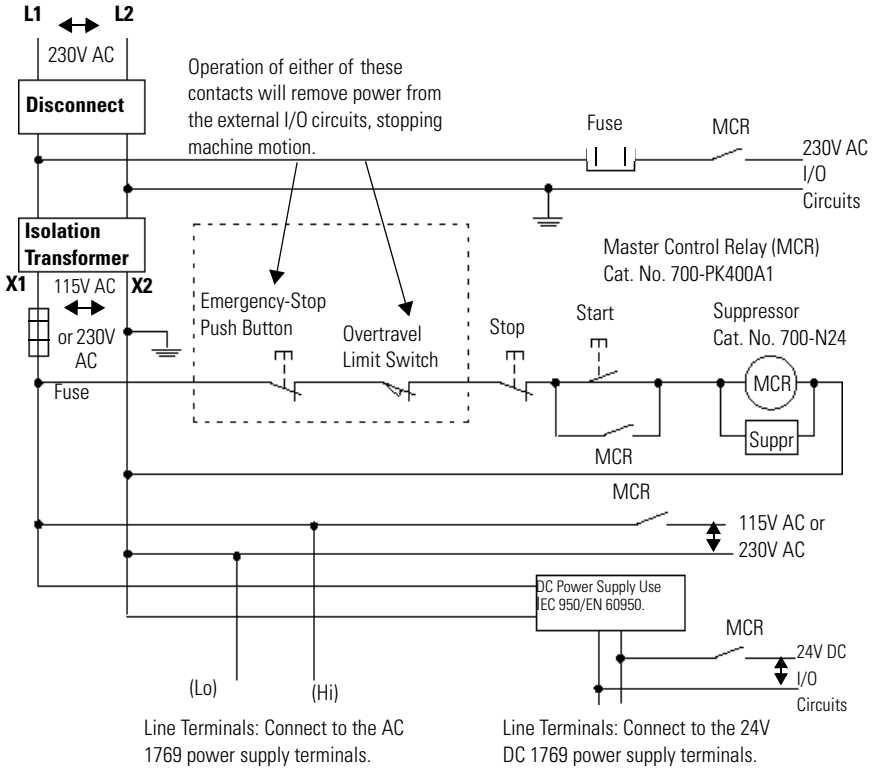

Schematic (Using ANSI/CSA Symbols)

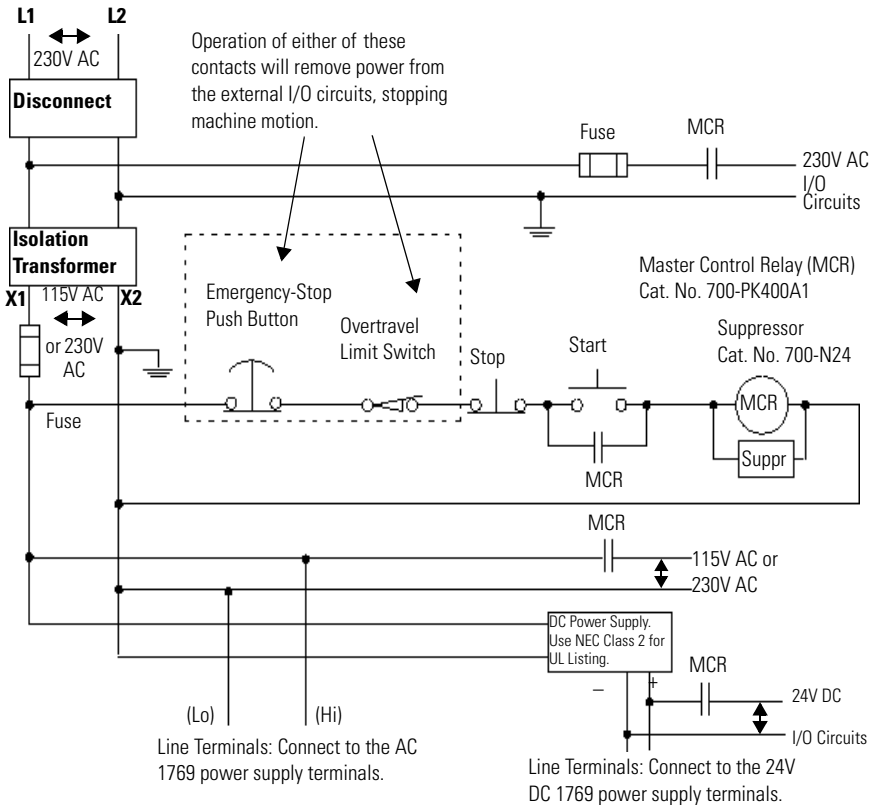

Connect the Power Supplies

Compact I/O system architecture and the power supply design support connection of I/O on either side of the power supply. Each I/O bank requires its own power supply.

To connect 2 I/O banks, attach a 1769 expansion I/O cable to a power supply or I/O module as shown in the [Power Supply Connection](#) illustration. Up to 8 I/O modules can be connected on either side (A or B in the illustration) of the power supply for a maximum of 16 modules per bank.

Each 1769 I/O module has a power supply distance rating, with a maximum value of eight. Refer to the specific 1769 I/O module's installation instructions for more information.

Power Supply Connection

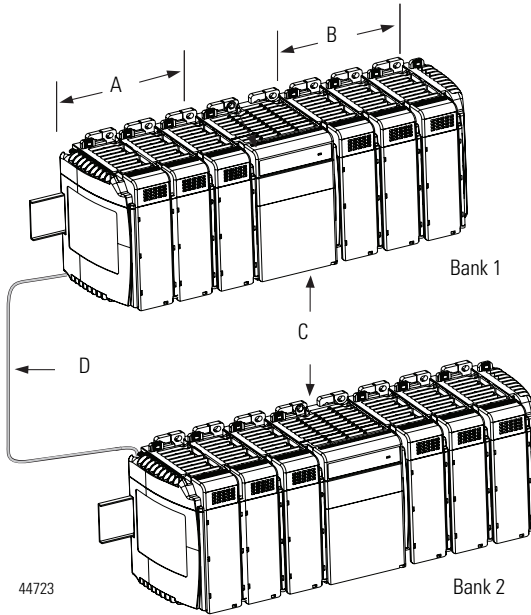

Item	Description
A - B	The maximum amount of bus current that can be distributed on the 1769 bus (on either side of the power supply, A or B) is: <ul style="list-style-type: none"> • 2 amps at 5V DC (assume supported by power supply) • 1 amp at 24V DC (assume supported by power supply)
C	Expansion I/O power supplies
D	I/O communication expansion cable

IMPORTANT To use a 1769 expansion I/O power supply with a controller that has an embedded power supply (for example, MicroLogix 1500), you must use a 1769 expansion I/O cable. Do not directly attach the expansion power supply to a controller that has an embedded power supply.

Connect Field Wires

The following instructions explain how to wire your power supply.

Ground the Power Supply

ATTENTION



This product is intended to be mounted to a well-grounded mounting surface such as a metal panel. Additional grounding connections from the power supply's mounting tabs or DIN rail (if used) are not required unless the mounting surface cannot be grounded. Refer to Industrial Automation Wiring and Grounding Guidelines, Allen-Bradley publication [1770-4.1](#), for additional information.

Wire the Power Supply

1. **1769-PA4 only** - Set the V AC line input power switch behind the clear door to match your 120V or 240V AC power source as directed by the **DANGER** label on the power supply.

The switch is shipped from the factory in the 240V AC position. Remove the selector switch label that covers the connectors after setting the proper power switch.

2. Connect the ground screw of the power supply to the nearest ground or ground bus.

Use a 2.5 mm² (14 AWG) wire and keep the leads as short as possible.

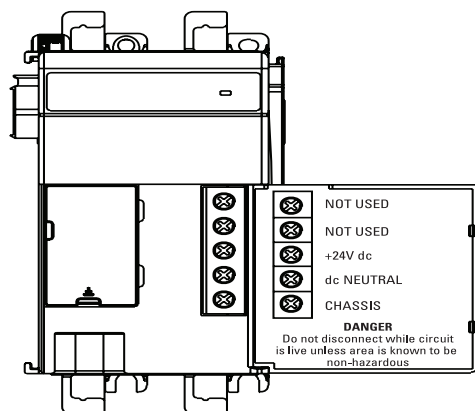







TIP







This  symbol denotes a protective earth ground terminal that provides a low impedance path between electrical circuits and earth for safety purposes and provides noise immunity improvement. This connection must be made for safety purposes.

3. Connect incoming power to the power supply terminals as indicated below.







Catalog Number 1769-PB2, 1769-PB4

	NOT USED
	NOT USED
	+24V DC
	DC NEUTRAL
	CHASSIS GROUND 

Catalog Number 1769-PA2

	PWR OUT +24V DC ⁽¹⁾
	PWR OUT COM ⁽¹⁾
	120/240V AC (L1)
	V AC COM (L2)
	CHASSIS GROUND 

Catalog Number 1769-PA4

	NOT USED
	NOT USED
	120/240V AC (L1)
	V AC COM (L2)
	CHASSIS GROUND 

ATTENTION



Turn off incoming power before connecting or disconnecting wires. Failure to do so could cause injury to personnel and/or damage to equipment.

(1) 24V DC user power for sensors or other special 24V DC I/O devices

Wire the Finger-safe Terminal Block

When wiring the terminal block, keep the finger-safe cover in place.

1. Loosen the terminal screws to be wired.

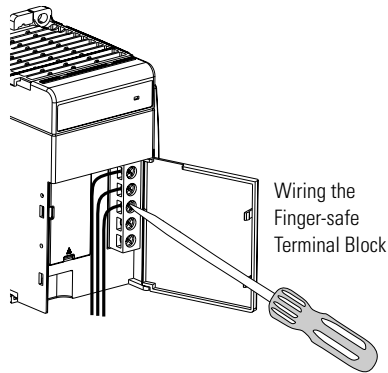

2. Route the wire under the terminal pressure plate.

You can use the bare wire or a spade lug. The terminals will accept a 6.35 mm (0.25 in.) spade lug.

TIP

The terminal screws are non-captive. Therefore, it is possible to use a ring lug [maximum 1/4-inch o.d. with a 0.139-inch minimum i.d. (M3.5)] with the module.

3. Tighten the terminal screw making sure the pressure plate secures the wire.

Recommended torque when tightening terminal screws is 1.27 N•m (11.24 lb•in).

TIP

If you need to remove the finger-safe cover, insert a screwdriver into one of the square wiring holes and gently pry the cover off. If you wire the terminal block with the finger-safe cover removed, you will not be able to put it back on the terminal block because the wires will be in the way.

Wire Size and Terminal Screw Torque

Each terminal accepts as many as two wires with the following restrictions.

Wire Type		Wire Size	Terminal Screw Torque
Solid	Cu-90 °C (194 °F)	2.5 mm ² (14 AWG)	1.27 N•m (11.24 lb•in)

Replace the Fuse

ATTENTION

Never install, remove, or wire power supplies unless power has been switched off.



Follow these steps to replace a blown fuse.

1. Remove Compact I/O system power to correct conditions causing the short circuit.
2. Place a slotted screwdriver under the tab to remove the fuse housing cover.
3. Use a fuse puller or similar device to remove the fuse.

Use care so that the printed circuit board and surrounding electronics are not damaged.

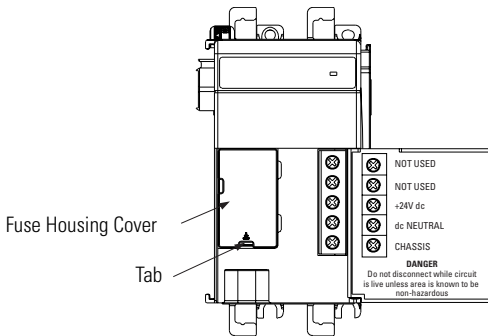

4. Replace the front access fuse by centering the replacement fuse over the fuse clip and pressing down.

See [Specifications](#) for information on the front access fuse.

If you use a tool to press the fuse in place, apply pressure to only the metal end caps, not to the center of the fuse.

5. Replace the fuse housing cover.
6. Restore Compact I/O system power.

Temperature Derating

The following graphs indicate how much current can be drawn from the power supply at the indicated case temperature without damaging it.

1769-PA2 Output Derating

With User +24V Current Draw at 0 Amps

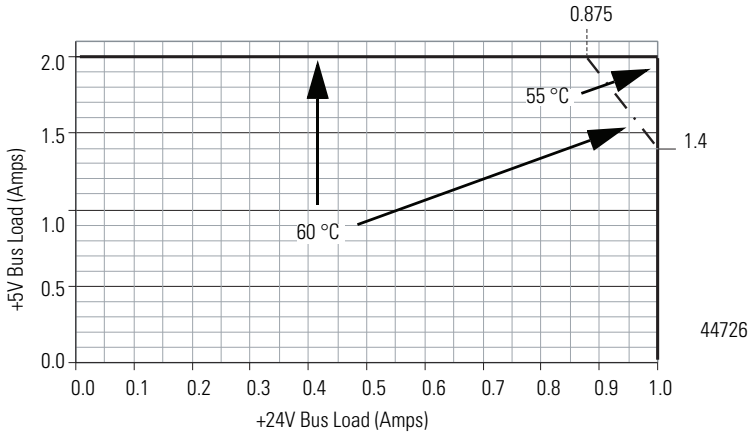

With User +24V Current Draw at 0.2 Amps

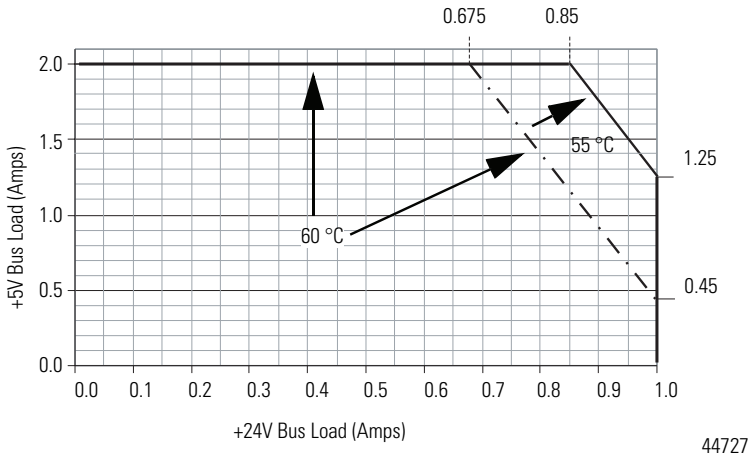

With User +24V Current Draw at 0.25 Amps

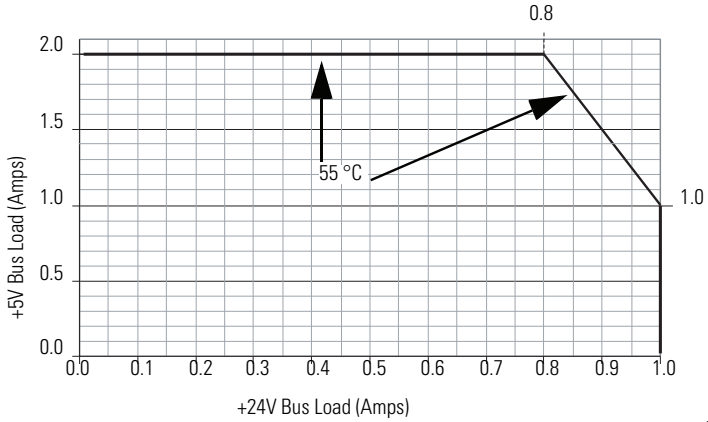

44728

1769-PB2 Output Derating

Total Output: 29 W at 60 °C (140 °F) or below

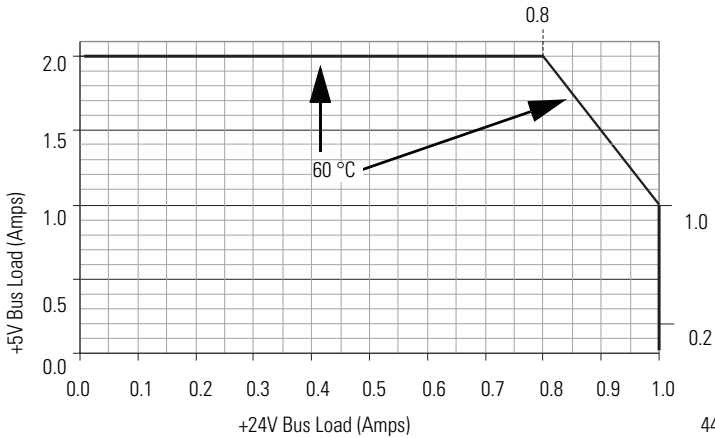

44729

1769-PA4 Output Derating

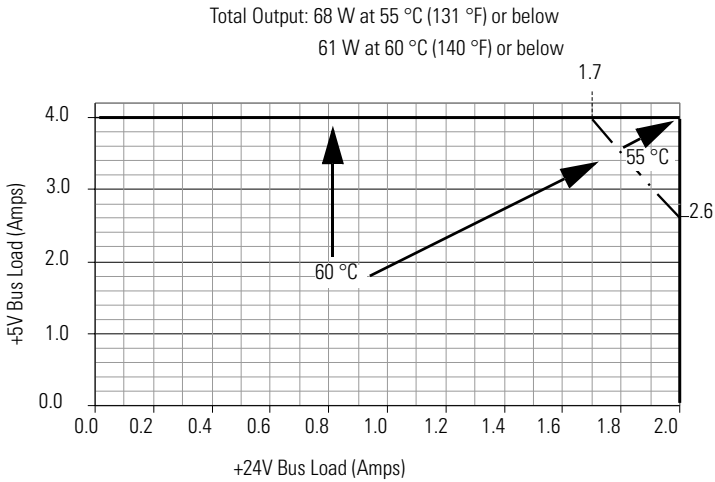

1769-PB4 Output Derating

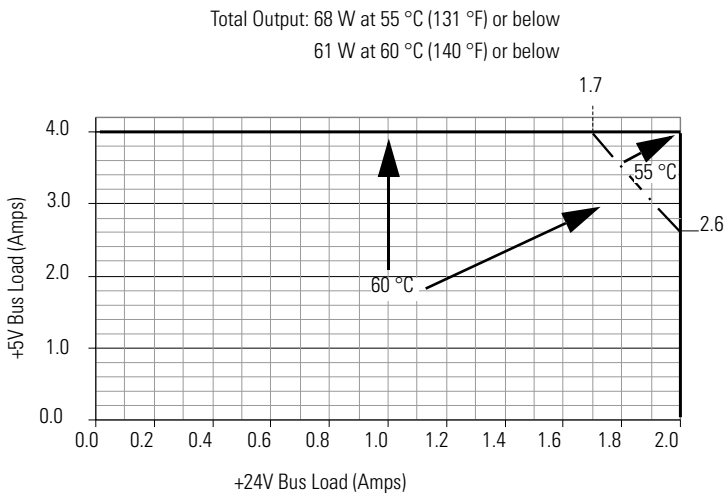

Power Dissipation

The following graphs indicate the real electrical power dissipation of the power supply in function of the electrical load.

1769-PA2 Real Power Dissipation

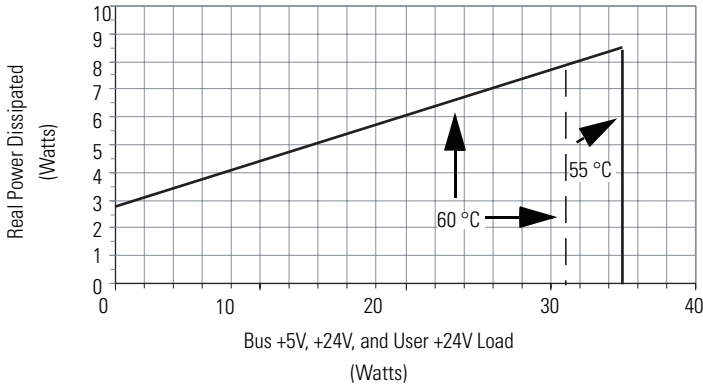

44730

1769-PB2 Real Power Dissipation

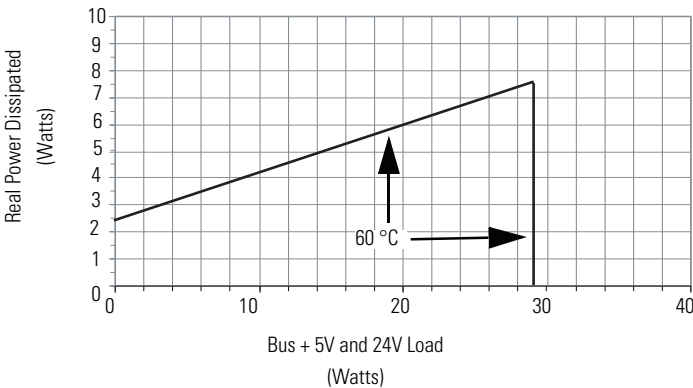

44731

1769-PA4 Real Power Dissipation

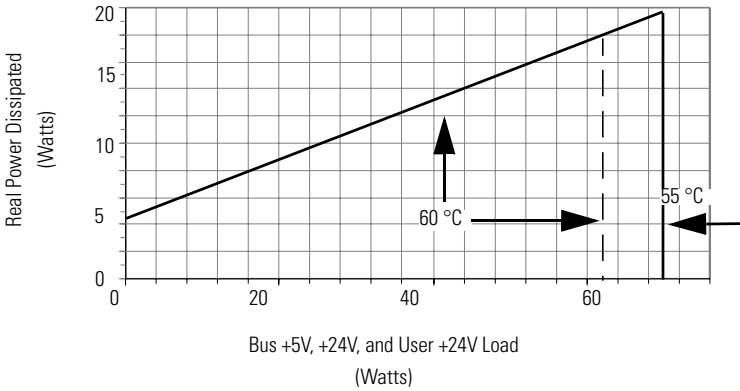

1769-PB4 Real Power Dissipation

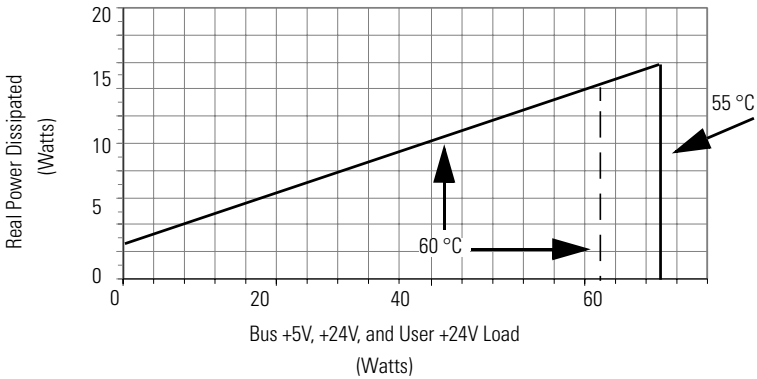

Specifications

1769-PA2, 1769-PB2, 1769-PA4, 1769-PB4 - Technical Specifications

Attribute	1769-PA2	1769-PB2	1769-PA4	1769-PB4
Input voltage range	85...265V AC	19.2...31.2V DC	85...132V AC or 170...265V AC, switch selectable	19.2...32V DC
Input frequency range	47...63 Hz	N/A	47...63 Hz	N/A
Power supply distance rating ⁽¹⁾	8 (8 I/O modules can be connected on either side of the power supply for a maximum of 16 modules.)			
Operating altitude	2000 m (6562 ft)			
Isolation voltage	265V (continuous), Reinforced Insulation Type (IEC Class 1 grounding required) Routine tested at 2596V DC for 1s, AC Power Input to System and AC Power Input to 24V DC User Power	75V (continuous), Reinforced Insulation Type (IEC Class 1 grounding required) Routine tested at 1697V DC for 1s, DC Power Input to System	265V (continuous), Reinforced Insulation Type (IEC Class 1 grounding required) Routine tested at 2596V DC for 1s, AC Power Input to System	75V (continuous), Reinforced Insulation Type (IEC Class 1 grounding required) Routine tested at 1697V DC for 1s, DC Power Input to System
Power consumption	100 VA @ 120V AC 130 VA @ 240V AC	50 VA @ 24V DC	200 VA @ 120V AC 240 VA @ 240V AC	100 VA @ 24V DC
Power dissipation	8 W @ 60 °C	7.5 W @ 60 °C	18 W @ 60 °C	14.5 W @ 60 °C
Current capacity at 5V	2.0 A	2.0 A	4.0 A	4.0 A
Current capacity at 24V	0.8 A	0.8 A	2.0 A	2.0 A
Inrush current, max	25 A @ 132V AC	30 A @ 31.2V DC	25 A @ 132V AC	30 A @ 31.2V DC
Fuse type	Wickmann 19195-3.15A Littelfuse 02183.15MXP	Wickmann 19193-6.3A Littelfuse 021706.3MXP	Wickmann 19195-3.15A Littelfuse 02183.15MXP	Wickmann 19193-6.3A Littelfuse 021706.3MXP
Dimensions (HxWxD), approx.	118 x 70 x 87 mm (4.65 x 2.76 x 3.43 in.) height including mounting tabs is 138 mm (5.43 in.)			
Shipping weight, approx	525 g (1.16 lb)		630 g (1.39 lb)	
Wiring category ⁽²⁾	1 on power ports	2 on power ports	1 on power ports	2 on power ports

1769-PA2, 1769-PB2, 1769-PA4, 1769-PB4 - Technical Specifications

Attribute	1769-PA2	1769-PB2	1769-PA4	1769-PB4
Wire size	2.5 mm ² (14 AWG) solid copper wire rated at 90 °C (194 °F), or greater, 1.2 mm (3/64 in.) insulation max			
North American temp code	T3C			
IEC temp code	N/A	T4	N/A	T4
Enclosure type rating	None (open style)			

(1) When configuring your system using a MicroLogix 1500 controller, only one expansion cable, one expansion power supply and a total of eight I/O modules may be used in a maximum of two banks of I/O modules. The expansion power supply cannot be directly connected to the MicroLogix 1500 controller.

(2) Use this Conductor Category information for planning conductor routing. Refer to Industrial Automation Wiring and Grounding Guidelines, publication [1770-4.1](#).

1769-PA2, 1769-PB2, 1769-PA4, 1769-PB4 - Environmental Specifications

Attribute	1769-PA2	1769-PB2	1769-PA4	1769-PB4
Operating temperature IEC 60068-2-1 (Test Ad, Operating Cold) IEC 60068-2-2 (Test Bd, Operating Dry Heat) IEC 60068-2-14 (Test Nb, Operating Thermal Shock)	0...60 °C (32...140 °F)			
Nonoperating temperature IEC 60068-2-1 (Test Ab, Unpackaged Nonoperating Cold) IEC 60068-2-2 (Test Bb, Unpackaged Nonoperating Dry Heat) IEC 60068-2-14 (Test Na, Unpackaged Thermal Shock)	-40...85 °C (-40...185 °F)			
Relative humidity IEC 60068-2-30 (Test Db, Unpackaged Damp Heat)	5...95% noncondensing			

1769-PA2, 1769-PB2, 1769-PA4, 1769-PB4 - Environmental Specifications

Attribute	1769-PA2	1769-PB2	1769-PA4	1769-PB4
Vibration IEC 60068-2-6 (Test Fc, Operating)	5 g @ 10...500 Hz			
Operating shock IEC 60068-2-27 (Test Ea, Unpackaged Shock)	DIN rail mount: 20 g; Panel Mount 30 g			
Nonoperating shock IEC 60068-2-27 (Test Ea, Unpackaged Shock)	DIN rail mount: 30 g; Panel Mount 40 g			
Emissions CISPR 11	Group 1, Class A			
ESD immunity IEC61000-4-2	4 kV contact, 8 kV air discharges			
Radiated RF immunity IEC61000-4-3	10V/m with 1 kHz sine-wave 80% AM from 80...2000 MHz 3V/m with 1 kHz sine-wave 80% AM from 2000...2700 MHz 10V/m with 200 Hz 50% Pulse 100% AM at 900 MHz 10V/m with 200 Hz 50% Pulse 100% AM at 1890 MHz	10V/m with 1 kHz sine-wave 80%AM from 80...2000 MHz 10V/m with 200 Hz 50% Pulse 100%AM at 900 MHz	10V/m with 1 kHz sine-wave 80% AM from 80...2000 MHz 3V/m with 1 kHz sine-wave 80% AM from 2000...2700 MHz 10V/m with 200 Hz 50% Pulse 100% AM at 900 MHz 10V/m with 200 Hz 50% Pulse 100% AM at 1890 MHz	10V/m with 1 kHz sine-wave 80%AM from 80...2000 MHz 10V/m with 200 Hz 50% Pulse 100%AM at 900 MHz
EFT/B immunity IEC 61000-4-4	±2 kV at 5 kHz on AC power ports ±2 kV at 5 kHz on 24V DC PWR OUT ports	±2 kV at 5 kHz on DC power ports	±2 kV at 5 kHz on AC power ports	±2 kV at 5 kHz on DC power ports
Surge transient immunity IEC61000-4-5	±2 kV line-line (DM) and ±4 kV line-earth (CM) on AC power ports ±500V line-line (DM) and ±500V line-earth (CM) on 24V DC PWR OUT ports	±500V line-line (DM) and ±500V line-earth (CM) on DC power ports	±2 kV line-line (DM) and ±4 kV line-earth (CM) on AC power ports	±500V line-line (DM) and ±500V line-earth (CM) on DC power ports

1769-PA2, 1769-PB2, 1769-PA4, 1769-PB4 - Environmental Specifications

Attribute	1769-PA2	1769-PB2	1769-PA4	1769-PB4
Conducted RF Immunity IEC61000-4-6	10V rms with 1kHz sine-wave 80% AM from 150 kHz...80 MHz			
Voltage Variation IEC 61000-4-11	30% dips for 1 period at 0° and 180° on AC supply ports 60% dips for 5 and 50 periods on AC supply ports ±10% fluctuations for 15 min on AC supply ports >95% interruptions for 250 periods on AC supply ports	N/A	30% dips for 1 period at 0° and 180° on AC supply ports 60% dips for 5 and 50 periods on AC supply ports ±10% fluctuations for 15 min on AC supply ports >95% interruptions for 250 periods on AC supply ports	N/A

1769-PB2, 1769-PB4 - Certifications⁽¹⁾

Certifications ⁽²⁾	Value
c-UL-us	UL Listed for Class 1, Division 2 Group A,B,C,D Hazardous Locations, certified for U.S. and Canada. See UL File E10314
CE	European Union 2004/108/EC EMC Directive, compliant with: <ul style="list-style-type: none"> • EN 61000-6-2; Industrial Immunity • EN 61000-6-4; Industrial Emissions
C-Tick	Australian Radio Communications Act, compliant with: <ul style="list-style-type: none"> • AS/NZS CISPR 11; Industrial Emissions
Ex	European Union 94/9/EC ATEX Directive, compliant with: <ul style="list-style-type: none"> • EN 60079-15; Potentially Explosive Atmospheres, Protection "n" (II 3 G Ex nA IIC T4 X) • EN 60079-0; General Requirements (Zone 2)

⁽¹⁾ When product is marked.⁽²⁾ See the Product Certification link at <http://www.ab.com> for Declarations of Conformity, Certificates, and other certification details.**1769-PA2, 1769-PA4 - Certifications⁽¹⁾**

Certifications ⁽²⁾	Value
c-UL-us	UL Listed for Class 1, Division 2 Group A,B,C,D Hazardous Locations, certified for U.S. and Canada. See UL File E10314

1769-PA2, 1769-PA4 - Certifications⁽¹⁾

Certifications ⁽²⁾	Value
CE	European Union 2004/108/EC EMC Directive, compliant with: <ul style="list-style-type: none">• EN 61000-6-2; Industrial Immunity• EN 61000-6-4; Industrial Emissions
C-Tick	Australian Radio Communications Act, compliant with: <ul style="list-style-type: none">• AS/NZS CISPR 11; Industrial Emissions

⁽¹⁾ When product is marked.

⁽²⁾ See the Production Certification link at <http://www.ab.com> for Declarations of Conformity, Certificates, and other certification details.

Certifications Compatibility with MicroLogix 1500

To use the 1769 expansion I/O power supply with the MicroLogix 1500 processor, the processor (catalog number 1764-LSP or 1764-LRP) must be series A, revision C, Firmware Revision Number (FRN) 3 or higher. You can check the firmware revision by looking at the processor nameplate.

Status file bit S:59 (Operating System Firmware Revision Number)

If your processor is at an older revision, you must upgrade the operating system. On the Internet, go to <http://www.ab.com/programmablecontrol/plc/micrologix/downloads.html> to download the firmware upgrade.

Additional Resources

These documents contain additional information concerning related Rockwell Automation products.

Resource	Description
1769-ADN Adapter User Manual, publication 1769-UM001	A more detailed description of how to install and use a 1769-ADN DeviceNet Adapter Module
Compact 1769 Analog I/O User Manual, publication 1769-UM002	A more detailed description of how to install and use Compact Analog I/O
CompactLogix System User Manual, publication 1769-UM007	A more detailed description of how to install and use your CompactLogix controller
MicroLogix 1500 Programmable Controllers User Manual, publication 1764-UM001	A more detailed description of how to install and use your Compact I/O with the MicroLogix 1500 programmable controller
CompactLogix Controllers Selection Guide, publication 1769-SG001	A more detailed description of the 1769 CompactLogix controllers
Compact I/O Selection Guide, publication 1769-SG002	A more detailed description of the 1769 I/O modules available with the Compact I/O system
Compact I/O Communication Bus Expansion Cables Installation Instructions, publication 1769-IN014	Information on installing and using Compact I/O Communication Bus Expansion Cables
Compact I/O End Caps/Terminators, publication 1769-IN015	Information on installing and using Compact 1769-ECL, 1769-ECR End Cap/Terminators
Industrial Automation Wiring and Grounding Guidelines, publication 1770-IN041	More information on proper wiring and grounding techniques

Rockwell Automation Support

Rockwell Automation provides technical information on the Web to assist you in using its products. At <http://www.support.rockwellautomation.com>, you can find technical manuals, a knowledge base of FAQs, technical and application notes, sample code and links to software service packs, and a MySupport feature that you can customize to make the best use of these tools.

For an additional level of technical phone support for installation, configuration and troubleshooting, we offer TechConnect support programs. For more information, contact your local distributor or Rockwell Automation representative, or visit <http://www.support.rockwellautomation.com>.

Installation Assistance

If you experience a problem within the first 24 hours of installation, please review the information that's contained in this manual. You can also contact a special Customer Support number for initial help in getting your product up and running.

United States	1.440.646.3434 Monday – Friday, 8 a.m. – 5 p.m. EST
Outside United States	Please contact your local Rockwell Automation representative for any technical support issues.

New Product Satisfaction Return

Rockwell Automation tests all of its products to ensure that they are fully operational when shipped from the manufacturing facility. However, if your product is not functioning and needs to be returned, follow these procedures.

United States	Contact your distributor. You must provide a Customer Support case number (call the phone number above to obtain one) to your distributor in order to complete the return process.
Outside United States	Please contact your local Rockwell Automation representative for return procedure.

Allen-Bradley, Compact I/O, CompactLogix, MicroLogix, Rockwell Automation, and TechConnect are trademarks of Rockwell Automation, Inc.

Trademarks not belonging to Rockwell Automation are property of their respective companies.

www.rockwellautomation.com

Power, Control and Information Solutions Headquarters

Americas: Rockwell Automation, 1201 South Second Street, Milwaukee, WI 53204-2496 USA. Tel: (1) 414.382.2000, Fax: (1) 414.382.4444

Europe/Middle East/Africa: Rockwell Automation, Vorstlaan/Boulevard du Souverain 36, 1170 Brussels, Belgium. Tel: (32) 2 663 0600, Fax: (32) 2 663 0640

Publication 1769-IN028B-EN-P - October 2008

Supersedes Publication 1769-IN028A-EN-P - April 2000

PN 33151

Copyright © 2008 Rockwell Automation, Inc. All rights reserved. Printed in the U.S.A.

